



1160 Nicole Court  
 Glendora, CA 91740  
 800-735-5566 • 909-592-6272  
 Fax: 909-592-7971  
 www.carsonind.com

**Specification Grade**

**1017**

**12" Inverted Box**

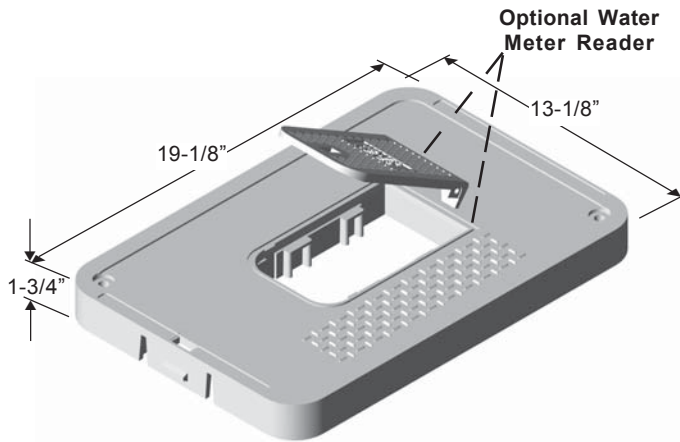

**3/8" Hex Bolt is optional**

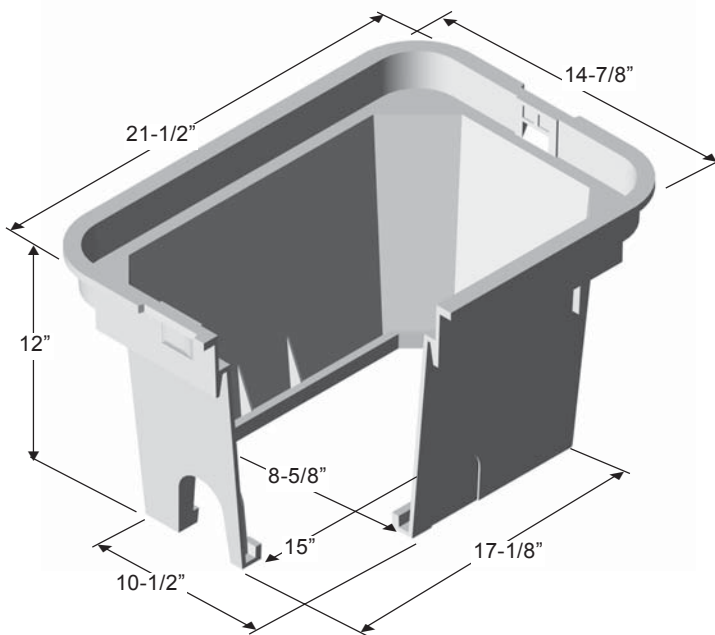

**FLUSH COVER**

**Models:**

- 1017-3 Green  
Gray  
Black
- 1017-5 Green or Gray  
With Plastic Reader
- 1017-6 Cast Iron  
With Cast Iron Reader

**BODY**

**Model:**

- 1017-12 Green  
Gray  
Black

**Note:** For use in non-vehicular traffic situations only. We do not recommend installation in concrete or asphalt. Weights and dimensions may vary slightly.

All information contained in this brochure was current at the time of printing. Because of Carson Industries' policy of ongoing research and development, the Company reserves the right to discontinue or update product information without notice.

## Specification Grade

# 1017

## 12" Inverted Box

### Carson Industries, LLC

1160 Nicole Court  
Glendora, CA 91740  
800-735-5566 • 909-592-6272  
Fax: 909-592-7971  
www.carsonind.com

### HDPE Structural Foam

#### RAW MATERIAL SPECIFICATIONS

Material Property	ASTM Test Method	Typical Value <sup>1</sup>
Type, Class, Category	D 1248	III, A, 3
Density, g/ cm <sup>3</sup>	D 1505	0.950 min., not to exceed 0.965
Tensile Strength, at break, psi	D 638	3,000 to 4,400
Elongation, at break, %	D 638	400
Tensile Impact, ft-lb/in <sup>2</sup>	D 1822	27
Flexural Modulus, psi	D 790	120,000 min., not to exceed 240,000
Low Temperature Brittleness, F50, at °C	D 746	<-76
Hardness, Shore D	D 2240	66
Deflection Temperature, at 66 psi	D 648	150° min., not to exceed 200°
Electrical Dielectric Strength, V/mil	D 149	400 min., not to exceed 600

#### Molded Product<sup>2</sup>

Chemical Resistance	D 543	Very Resistant
Water Absorption	D 570	Less than 1% weight change

<sup>1</sup>The values listed for physical property measurements are nominal values only. Certain physical property measurements are subject to variations consistent with the test methods and are within a generally accepted range for such values.

<sup>2</sup>Test reports available on request.

12/18/02

#### SHIPPING INFORMATION

	<b>Weight</b>
1017-3,-5 Covers	3.6 lbs.
1017-6 Cover	4.0 lbs.
1017-12 Body	6.4 lbs.

#### Shipping Configuration

Unit, 66 assemblies = 56.0 cu. ft.; 756.0 lbs.

All information contained in this brochure was current at the time of printing. Because of Carson Industries' policy of ongoing research and development, the Company reserves the right to discontinue or update product information without notice.