



**Glendora, California**

Toll-Free: 800.735.5566

Phone: 909.592.6272

Fax: 909.592.7971

**Roscommon, Ireland**

Phone: 35.39.03.25922

Fax: 35.39.03.25921

# H Series H3048

## Heavy Duty

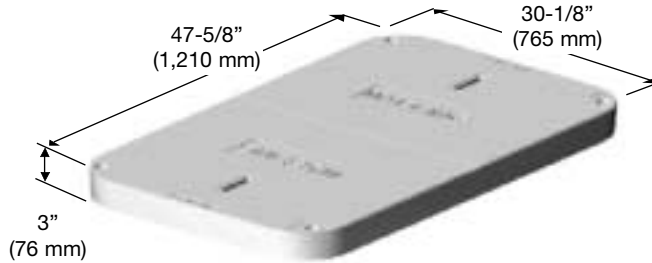

**Cover<sup>1</sup> (2 piece)**

Material: Polymer Concrete

Weight: 144.0 lbs. (65.3 kgs) per half cover

Model: H3048-P1

Skid Resistant Surface<sup>2</sup>

(Material and cover dimensions compliant with WUC, Guide 3.6<sup>3</sup>)

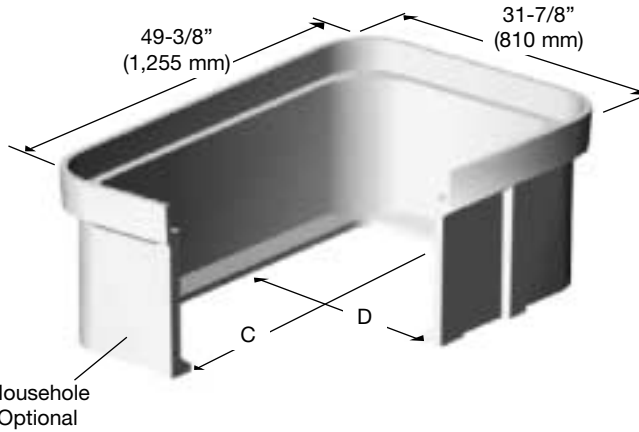

**Bodies (18", 24", 30", 36")**

Material: Polymer Concrete

- 18" Weight: 165 lbs. (75 kg)  
Model: H3048-18

- 24" Weight: 220 lbs. (100 kg)  
Model: H3048-24

- 30" Weight: 271 lbs. (122 kg)  
Model: H3048-30

- 36" Weight: 314 lbs. (141 kg)  
Model: H3048-36

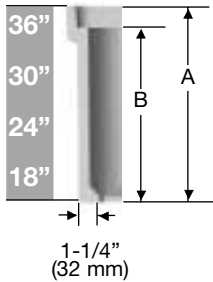

	A	B	C	D
<b>H3048-18</b>	18" (457 mm)	15" (381 mm)	41-3/8" (1051 mm)	23-7/8" (606 mm)
<b>H3048-24</b>	24" (610 mm)	21" (533 mm)	41-5/16" (1049 mm)	23-13/16" (605 mm)
<b>H3048-30</b>	30" (762 mm)	27" (686 mm)	41-3/16" (1045 mm)	23-11/16" (601 mm)
<b>H3048-36</b>	36" (914 mm)	33" (838 mm)	41" (1041 mm)	23-1/2" (597 mm)

**Bottom Extension**

Material: Polymer Concrete

Model: H3048-9X (99.0 lbs. /45 kgs)

**Tolerances**

Cover  $\pm 1/8"$  (3 mm); Body  $\pm 1/8"$  (3 mm)

Foot  $\pm 1/16"$  (2 mm); Height  $\pm 1/4"$  (6 mm)

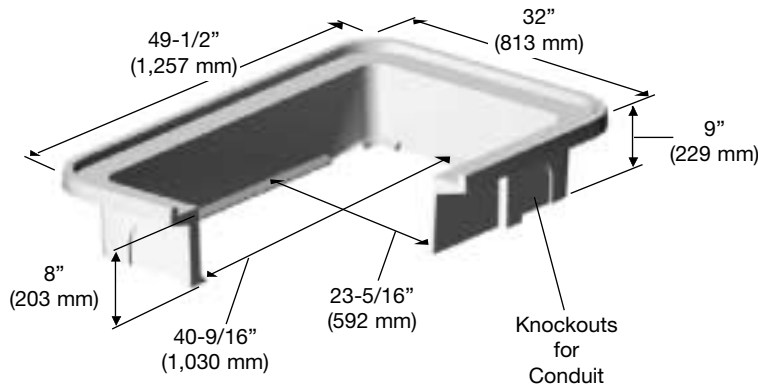

**Fasteners:** 2 each (optional 4 ea) 1/2-13 UNC, Stainless Steel, Hex Head with Washer; Options: Captive bolt and floating nut, size, quantity, type head are available.

**Cover Identification** is blank unless specified

**Pull Slot** 1/2" x 4" (13 mm x 102 mm)

**Steel Covers Optional**

**Boxes are stackable.** 24" deep shall be used as the lower box only. Vertical load ratings are stated for single boxes. For units with MOLDED OPENINGS, subtract 2 lbs from Unit Weight. Weights may vary slightly. Dimensions in inches with metric equivalents.

# H Series H3048

## Heavy Duty

## Carson Industries, LLC

**Glendora, California**  
Toll-Free: 800.735.5566  
Phone: 909.592.6272  
Fax: 909.592.7971

**Roscommon, Ireland**  
Phone: 35.39.03.25922  
Fax: 35.39.03.25921

### Vertical and Lateral Load Rating

#### Heavy Duty Covers

- Compliant with AASHTO, Design Load of H-10; ASTM C 857-95, Design Load of A-8, 8,000 lbs. Capable of withstanding a Static Load of >22,880 lbf transferred through a 10" x 10" steel plate centered on the cover and body.
- Compliant with AASHTO, Design Load of H-20; ASTM C 857-95, Design Load of A-16, 16,000 lbs. Capable of withstanding a Static Load of >45,760 lbf transferred through a 10" x 20" steel plate centered on the cover and body.
- This product is designed to withstand H-10 and H-20 loading in incidental or non-deliberate traffic areas. Not intended to be installed in roadways.

### Shipping Configuration

- Single Bodies – 18":**  
Unit, 2 assemblies, = 47.8 cu. ft.;  
906.0 lbs.
- Single Bodies – 24":**  
Unit, 2 assemblies, = 61.8 cu. ft.;  
1,016.0 lbs.

### Shipping Information

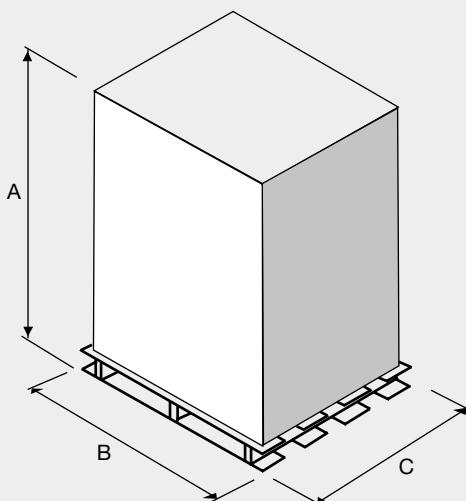

Standard Test Method	Properties of Raw Material	ASTM Designation	Test Results
Compressive Strength of Polymer Concretes	Compressive Strength	C 579-96	11,000 psi
Flexural Strength and Modulus of Elasticity of Polymer Concretes	Flexural Strength Modulus of Elasticity	C 580-93	1,800 psi 2,900,000 psi
Chemical Resistance of Polymer Concretes	Chemical Resistance	C 267-97	Pass <sup>4</sup>
Determination of Impact Resistance by means of a Tup (falling weight)	Impact Resistance	D 2444-93	Pass <sup>5</sup>

<sup>1</sup>AASHTO H-10, ASTM C 857, A-8, 8,000 lbs Design Load. Static Vertical Load Rating >22,880 lbf. AASHTO H-20, ASTM C 857 A-16, 16,000 lbs Design Load. Static Vertical Load Rating > 45,760 lbf

<sup>2</sup>Coefficient of Friction (ASTM C1028) >0.5

<sup>3</sup>Western Underground Committee, Guide 3.6

<sup>4</sup>Specimens exposed to ten reagents (alkalis, acids and petroleum distillates) experience <2% weight and dimensional change and retain >75% of average Compressive Strength. Listing of reagents and test reports available upon request.

<sup>5</sup>Capable of withstanding 70 ft lbs impact with a type "C" Tup.

UNIT 3048-18			UNIT 3048-24			UNIT 3048-30			UNIT 3048-36		
Dim.	Description	Value	Dim.	Description	Value	Dim.	Description	Value	Dim.	Description	Value
A	Height	42"	A	Height	54"	A	Height	36"	A	Height	42"
B	Length	42"	B	Length	42"	B	Length	42"	B	Length	42"
C	Width	54"	C	Width	54"	C	Width	54"	C	Width	54"
<b>Units:</b> 2 per pallet			<b>Units:</b> 2 per pallet			<b>Units:</b> 2 per pallet			<b>Units:</b> 2 per pallet		
<b>Weight:</b> 961 lbs. per pallet			<b>Weight:</b> 1,071 lbs. per pallet			<b>Weight:</b> 1,173 lbs. per pallet			<b>Weight:</b> 1,259 lbs. per pallet		
BODY 3048-18			BODY 3048-24			BODY 3048-30			BODY 3048-36		
Dim.	Description	Value	Dim.	Description	Value	Dim.	Description	Value	Dim.	Description	Value
A	Height	42"	A	Height	54"	A	Height	36"	A	Height	42"
B	Length	42"	B	Length	42"	B	Length	42"	B	Length	42"
C	Width	54"	C	Width	54"	C	Width	54"	C	Width	54"
<b>Units:</b> 4 per pallet			<b>Units:</b> 4 per pallet			<b>Units:</b> 2 per pallet			<b>Units:</b> 2 per pallet		
<b>Weight:</b> 715 lbs. per pallet			<b>Weight:</b> 935 lbs. per pallet			<b>Weight:</b> 597 lbs. per pallet			<b>Weight:</b> 683 lbs. per pallet		
COVER			BOTTOM EXTENSION			All information contained in this brochure was current at the time of printing. Because of Carson Industries' policy of ongoing research and development, the Company reserves the right to discontinue or update product information without notice.					
Dim.	Description	Value	Dim.	Description	Value						
A	Height	21"	A	Height	47"						
B	Length	42"	B	Length	42"						
C	Width	48"	C	Width	48"						
<b>Units:</b> 15 sets per pallet			<b>Units:</b> 5 per pallet								
<b>Weight:</b> 1,485 lbs. per pallet			<b>Weight:</b> 540 lbs. per pallet								