



Glendora, California

Toll-Free: 800.735.5566

Phone: 909.592.6272

Fax: 909.592.7971

Roscommon, Ireland

Phone: 35.39.03.25922

Fax: 35.39.03.25921

L Series 1730-18

Light Duty

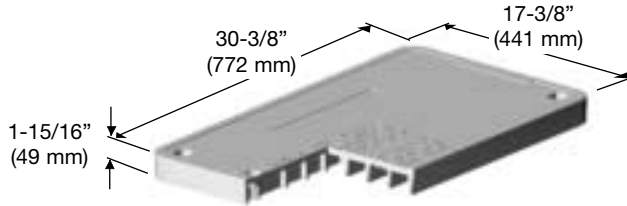

Flush Cover

Material: HDPE

Weight: 10.0 lbs.

Model: 1730-3B

Option: ABS

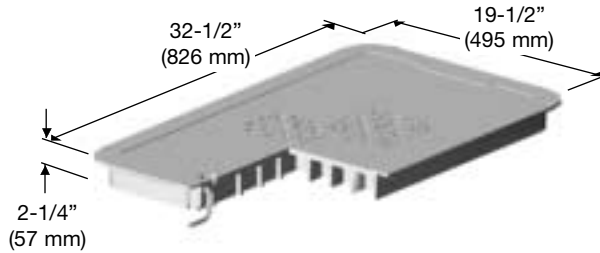

T-Cover

Material: HDPE

Weight: 10.0 lbs.

Model: 1730-4B Bolt Down

1730-4L Captive L-Bolt Lock

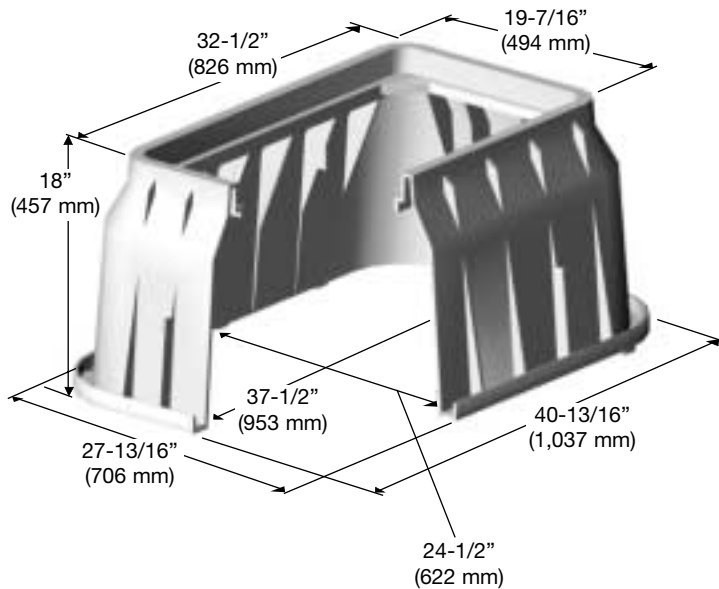

Body

Material: HDPE

Weight: 26.0 lbs.

Model: 1730-18

Colors Available

Green, Gray or Black

Note: For use in non-vehicular traffic situations only. We do not recommend installation in concrete or asphalt. Weights and dimensions may vary slightly.

L Series 1730-18

Light Duty

Static Vertical Load Rating (Design Load; Test Load)

- ASTM C857 – A-0.3, 300 lbf/ft²; Report Ultimate
- SCTE – Light Duty, Pedestrian; 3,000 lbf

Shipping Configuration

- Unit, 16 assemblies,
= 92.5 cu. ft., 717.0 lbs.

Carson Industries, LLC

Glendora, California

Toll-Free: 800.735.5566
Phone: 909.592.6272
Fax: 909.592.7971

Roscommon, Ireland

Phone: 35.39.03.25922
Fax: 35.39.03.25921

Material Property	ASTM Test	
	Method	Typical Value ¹
Type, Class, Category	D 1248	III, A, 3
Density, g/cm ³	D 1505	0.950 min., not to exceed 0.965
Tensile Strength, at break, psi	D 638	3,000 to 4,400
Elongation, at break, %	D 638	400
Tensile Impact, ft-lb/in ²	D 1822	27
Flexural Modulus, psi	D 790	120,000 min., not to exceed 240,000
Low Temperature Brittleness, F50, at °C	D 746	<-76
Hardness, Shore D	D 2240	66
Deflection Temperature, at 66 psi, °F	D 648	150° min., not to exceed 200°
Electrical Dielectric Strength, V/mil	D 149	400 min., not to exceed 600
Molded Product²		
Chemical Resistance	D 543	Very Resistant
Water Absorption	D 570	Less than 1% weight change

¹The values listed for physical property measurements are nominal values only. Certain physical property measurements are subject to variations consistent with the test methods and are within a generally accepted range for such values.
²Test reports available on request.

Shipping Information

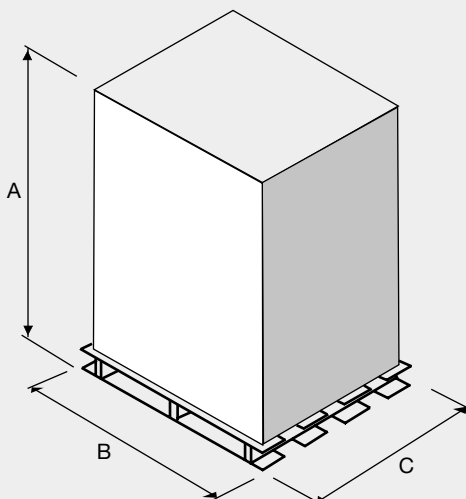

UNIT			FLUSH COVER			T-COVER		
Dim.	Description	Value	Dim.	Description	Value	Dim.	Description	Value
A	Height	80"	A	Height	66"	A	Height	73"
B	Length	40"	B	Length	40"	B	Length	40"
C	Width	48"	C	Width	48"	C	Width	48"

Units: 16 per pallet
Weight: 616 lbs. per pallet

Units: 120 per pallet
Weight: 1,240 lbs. per pallet

Units: 120 per pallet
Weight: 1,240 lbs. per pallet

BODY		
Dim.	Description	Value
A	Height	80"
B	Length	40"
C	Width	48"

Units: 16 per pallet
Weight: 456 lbs. per pallet

Note: For use in non-vehicular traffic situations only. We do not recommend installation in concrete or asphalt. Weights and dimensions may vary slightly.

All information contained in this brochure was current at the time of printing. Because of Carson Industries' policy of ongoing research and development, the Company reserves the right to discontinue or update product information without notice.