



Glendora, California

Toll-Free: 800.735.5566

Phone: 909.592.6272

Fax: 909.592.7971

Roscommon, Ireland

Phone: 35.39.03.25922

Fax: 35.39.03.25921

M Series F1730

Medium Duty

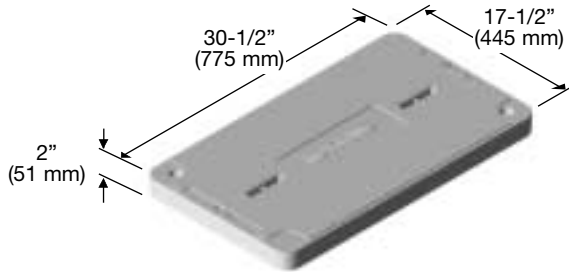

Floating Nut Assembly

Cover

Material: Polymer Concrete

Weight: 76.0 lbs. (34 kg)

Model: H1730-PC

Skid Resistant Surface

Material Compliant with WUC,
(Guide 3.6)

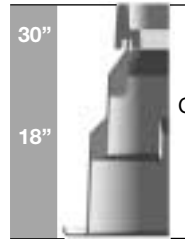
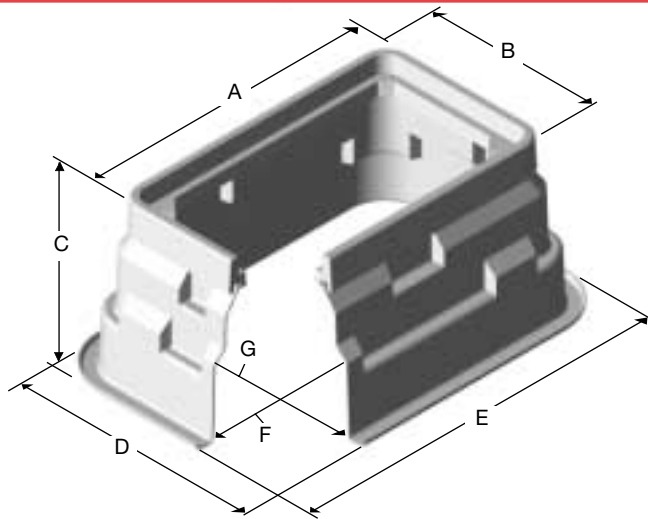

Body

Material: Fiberglass/Polymer Concrete

- 18" Weight: 45 lbs. (20.25 kg)
Model: F1730-18

- 30" Weight: 66 lbs. (30 kg)
Model: F1730-30

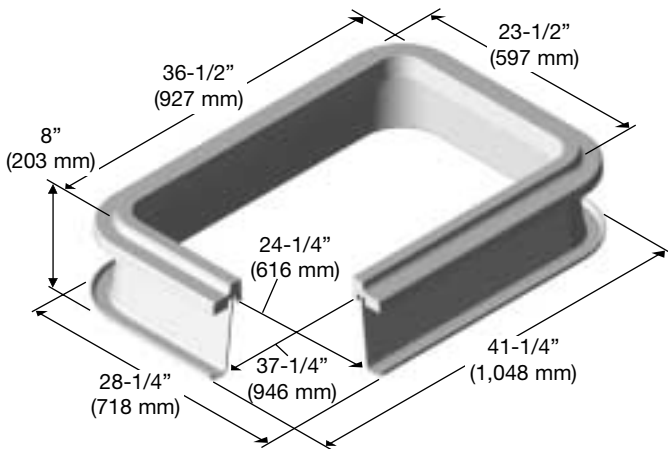

Extension - 8"

Material: Fiberglass/Polymer Concrete

Weight: 42 lbs. (19 kg)

Model: F1730-8X

	A	B	C	D	E	F	G
F1730-18	32-7/8" (835 mm)	19-7/8" (505 mm)	18" (457 mm)	27-3/4" (705 mm)	40-3/4" (1,035 mm)	36-3/4" (933 mm)	23-3/4" (603 mm)
F1730-30	32-7/8" (835 mm)	19-7/8" (505 mm)	30" (762 mm)	27-3/4" (705 mm)	40-3/4" (1,035 mm)	36-3/4" (933 mm)	23-3/4" (603 mm)

Note: For use in non-vehicular traffic situations only. Weights and dimensions may vary slightly.

Revision Date 4/2003

M Series F1730

Medium Duty

Static Vertical Load Rating (Design Load; Test Load)

- Tier 5 - 5,200 lbf.: 11,282 lbf
- WUC, Guide 3.6 - 10,400 lbf: Report Ultimate
- Meets or exceeds 20,000 lbf Static Vertical Load

Shipping Configuration

Carson Industries, LLC

Glendora, California

Toll-Free: 800.735.5566
Phone: 909.592.6272
Fax: 909.592.7971

Roscommon, Ireland

Phone: 35.39.03.25922
Fax: 35.39.03.25921

Properties of Base Material	ASTM Test Method	Typical Value
Tensile Strength, at break, PSI	D-2343	9,000
Flexural Modulus, 10 ³ , PSI	D-790	1,490
Density/gram cm ³	D-1505	1.7

Properties of Polymer Concrete Material

Flexural Strength	C-580	7,500 psi
Compression Strength	C-579	11,000 psi

Shipping Information

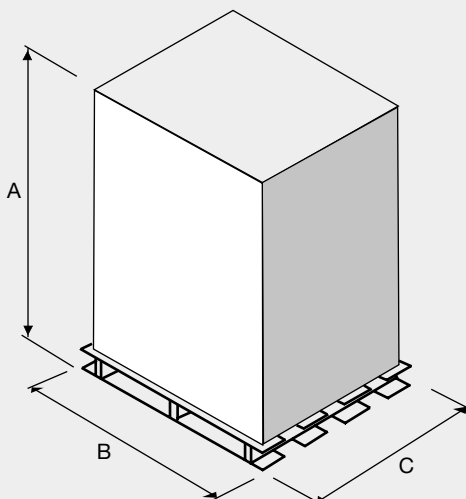

UNIT 1730-18			COVER 1730-18			BODY 1730-18		
Dim.	Description	Value	Dim.	Description	Value	Dim.	Description	Value
A	Height	56"	A	Height	46"	A	Height	56"
B	Length	42"	B	Length	42"	B	Length	42"
C	Width	48"	C	Width	48"	C	Width	54"

Units: 12 per pallet
Weight: 1,617 lbs. per pallet

Units: 69 per pallet
Weight: 3,150 lbs. per pallet

Units: 12 per pallet
Weight: 789 lbs. per pallet

UNIT 1730-30			COVER 1730-30			BODY 1730-30		
Dim.	Description	Value	Dim.	Description	Value	Dim.	Description	Value
A	Height	53"	A	Height	46"	A	Height	53"
B	Length	42"	B	Length	42"	B	Length	42"
C	Width	54"	C	Width	48"	C	Width	54"

Units: 8 per pallet
Weight: 1,115 lbs. per pallet

Units: 69 per pallet
Weight: 3,150 lbs. per pallet

Units: 8 per pallet
Weight: 563 lbs. per pallet

Note: For use in non-vehicular traffic situations only. Weights and dimensions may vary slightly.

All information contained in this brochure was current at the time of printing. Because of Carson Industries' policy of ongoing research and development, the Company reserves the right to discontinue or update product information without notice.