



Glendora, California

Toll-Free: 800.735.5566

Phone: 909.592.6272

Fax: 909.592.7971

Roscommon, Ireland

Phone: 35.39.03.25922

Fax: 35.39.03.25921

M Series G1324-18

Medium Duty

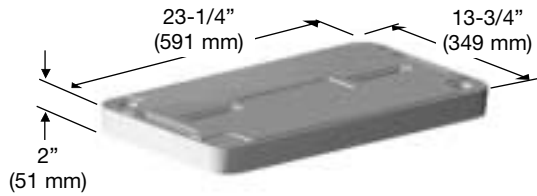

Cover

Material: Polymer Concrete

Weight: 36.0 lbs. (16.3 kg)

Model: G1324-PC

See *OPTIONS SECTION*:

– *Light Weight Cover*

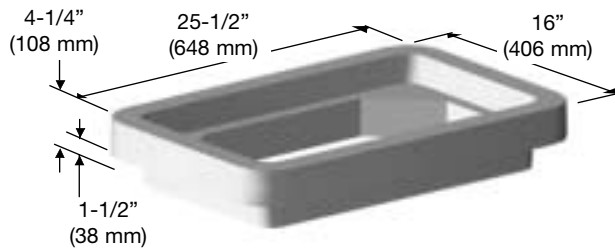

Ring

Material: Polymer Concrete

Weight: 39.0 lbs. (17.7 kg)

Model: G1324-PR

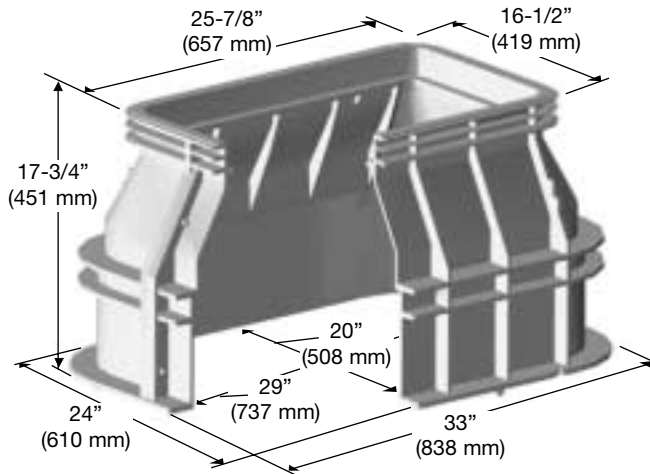

Body

Material: GF-HDPE

Weight: 25.0 lbs. (11.3 kg)

Model: G1324-18

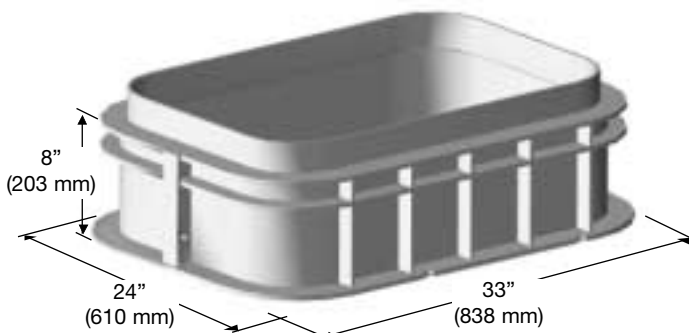

Extension
Made to order

Extensions

Material: GF-HDPE

– 8" Weight: 14 lbs. (6.3 kg)

Model: G1324-8X

Colors Available

Body – Gray

Cover and Ring – Gray or Green

Note: For use in non-vehicular traffic situations only. Weights and dimensions may vary slightly.

Revision Date 4/2003

M Series G1324-18

Medium Duty

Static Vertical Load Rating (Design Load; Test Load)

- Tier 5 – 5,200 lbf; 11, 282 lbf
- WUC, Guide 3.6 – 10,400 lbf; Report Ultimate

Shipping Configuration

- Unit, 10 assemblies,
= 83.0 cu. ft., 1,000.0 lbs.

Carson Industries, LLC

Glendora, California

Toll-Free: 800.735.5566
Phone: 909.592.6272
Fax: 909.592.7971

Roscommon, Ireland

Phone: 35.39.03.25922
Fax: 35.39.03.25921

Material Property	ASTM Test	
	Method	Typical Value ¹
Type, Class, Category	D 1248	III, A, 3
Density, g/cm ³	D 1505	0.950 min., not to exceed 0.965
Tensile Strength, at break, psi	D 638	3,000 to 4,400
Elongation, at break, %	D 638	400
Tensile Impact, ft-lb/in ²	D 1822	27
Flexural Modulus, psi	D 790	120,000 min., not to exceed 240,000
Low Temperature Brittleness, F50, at °C	D 746	<-76
Hardness, Shore D	D 2240	66
Deflection Temperature, at 66 psi, °F	D 648	150° min., not to exceed 200°
Electrical Dielectric Strength, V/mil	D 149	400 min., not to exceed 600

Molded Product²

Chemical Resistance	D 543	Very Resistant
Water Absorption	D 570	Less than 1% weight change

Properties of Polymer Concrete Material

Flexural Strength	C 580	7,500 psi
Compression Strength	C 579	11,000 psi

¹The values listed for physical property measurements are nominal values only. Certain physical property measurements are subject to variations consistent with the test methods and are within a generally accepted range for such values.
²Test reports available on request.

Shipping Information

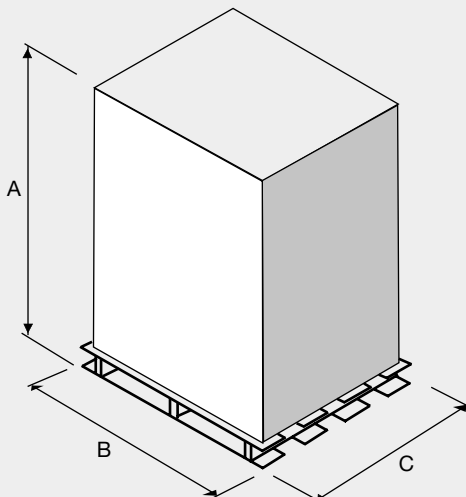

UNIT			COVER			RING		
Dim.	Description	Value	Dim.	Description	Value	Dim.	Description	Value
A	Height	66"	A	Height	45"	A	Height	46"
B	Length	40"	B	Length	42"	B	Length	42"
C	Width	48"	C	Width	48"	C	Width	48"

Units: 10 per pallet
Weight: 65 lbs. per pallet

Units: 100 per pallet
Weight: 3,645 lbs. per pallet

Units: 45 per pallet
Weight: 1,800 lbs. per pallet

BODY		
Dim.	Description	Value
A	Height	96"
B	Length	40"
C	Width	48"

Units: 14 per pallet
Weight: 390 lbs. per pallet

All information contained in this brochure was current at the time of printing. Because of Carson Industries' policy of ongoing research and development, the Company reserves the right to discontinue or update product information without notice.

Note: For use in non-vehicular traffic situations only. Weights and dimensions may vary slightly.