



1160 Nicole Court  
 Glendora, CA 91740  
 800-735-5566 • 909-592-6272  
 Fax: 909-592-7971  
 www.carsonind.com

## Drainage

# Channel Drain

## 90° Connection

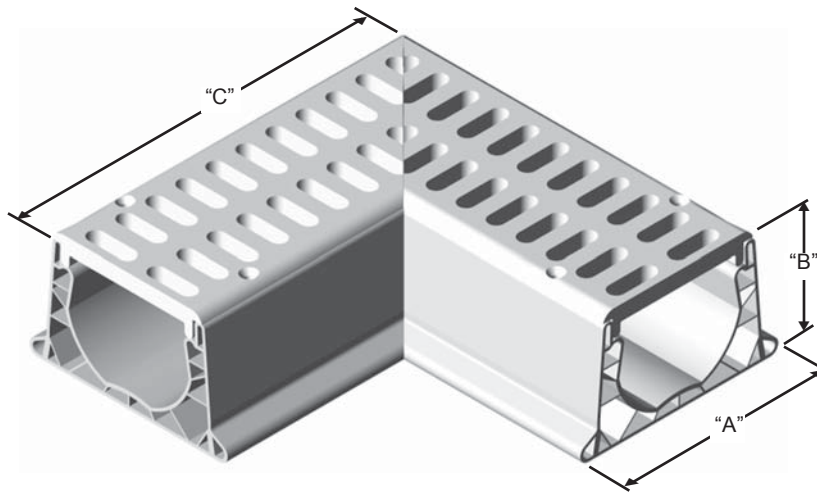

PRODUCT SIZE	A	B	C
2"	3-1/4"	2"	6"
4"	6-5/8"	3-13/16"	10-1/4"

### 2" 90° 1/4 BEND CONNECTION

#### Models:

TT-640 Green      TT-643 Tan  
 TT-641 Black  
 TT-642 Gray

#### Material:

Channel – PVC (Extrusion Grade)  
 Grates – High-Density Polyethylene

### 4" 90° 1/4 BEND CONNECTION

#### Models:

TT-771 Green      TT-774 Tan  
 TT-772 Black  
 TT-773 Gray

#### Material:

Channel – PVC (Extrusion Grade)  
 Grates – High-Density Polyethylene

### Installation Reference

*Recommended for light vehicular traffic such as cars and small trucks with speeds not exceeding 20 mph.*

*When installing in concrete, grate must be fastened to channel prior to installation. After support braces (#TT-637-2" or #TT-769-4") have been anchored to rebar, channel will remain securely in position when concrete is poured. For best results, a gentle slope of 1/8" per foot of concrete will provide good drainage into channel system.*

*For applications where concrete is not required, such as green areas, the channel system can be laid directly on a bed of crushed stone and backfilled with compacted soil.*

All information contained in this brochure was current at the time of printing. Because of Carson Industries' policy of ongoing research and development, the Company reserves the right to discontinue or update product information without notice.

## Drainage

# Channel Drain

## 90° Connection

### Carson Industries, LLC

1160 Nicole Court  
Glendora, CA 91740

800-735-5566 • 909-592-6272

Fax: 909-592-7971

www.carsonind.com

### HDPE STRUCTURAL FOAM

#### RAW MATERIAL SPECIFICATIONS

Material Property	ASTM Test Method	Typical Value <sup>1</sup>
Type, Class, Category	D 1248	III, A, 3
Density, g/ cm <sup>3</sup>	D 1505	0.950 min., not to exceed 0.965
Tensile Strength, at break, psi	D 638	3,000 to 4,400
Elongation, at break, %	D 638	400
Tensile Impact, ft-lb/in <sup>2</sup>	D 1822	27
Flexural Modulus, psi	D 790	120,000 min., not to exceed 240,000
Low Temperature Brittleness, F50, at °C	D 746	<-76
Hardness, Shore D	D 2240	66
Deflection Temperature, at 66 psi	D 648	150° min., not to exceed 200°
Electrical Dielectric Strength, V/mil	D 149	400 min., not to exceed 600

#### Molded Product<sup>2</sup>

Chemical Resistance	D 543	Very Resistant
Water Absorption	D 570	Less than 1% weight change

### POLYVINYL CHLORIDE, EXTRUSION GRADE

Material Property	ASTM Test Method	Typical Value <sup>1</sup>
Cell Classification	D 1784	16,354
Specific Gravity, g/cm <sup>3</sup>	D 792	1.46
Tensile Strength, at yield, psi	D 638	≥6,000
Tensile Modulus, psi	D 638	≥430,000
Flexural Modulus, psi	D 790	≥420,000
Dart Impact Resistance, @73° F, in-lb/mil, 0.125" conical dart	D 4226	1.1
Deflection Temperature, at 264 psi, °F	D648	163
Hardness, Shore D	D 2440	79

<sup>1</sup>The values listed for physical property measurements are nominal values only. Certain physical property measurements are subject to variations consistent with the test methods and are within a generally accepted range for such values.

<sup>2</sup>Test reports available on request.

12/18/02

#### SHIPPING INFORMATION

All information contained in this brochure was current at the time of printing. Because of Carson Industries' policy of ongoing research and development, the Company reserves the right to discontinue or update product information without notice.

	Carton Quantity	Weight
2" 90° 1/4 Bend Connection	1	1 lbs.
4" 90° 1/4 Bend Connection	1	2.28 lbs.