



1160 Nicole Court  
Glendora, CA 91740  
800-735-5566 • 909-592-6272  
Fax: 909-592-7971  
www.carsonind.com

# Heavy Duty HLW1212

## Polymer Concrete 12" Square H-10



### COVER<sup>1</sup>

#### Model:

HLW1212-P0

#### Skid Resistant Surface<sup>2</sup>

(Material and cover dimensions compliant with WUC, Guide 3.6<sup>3</sup>)

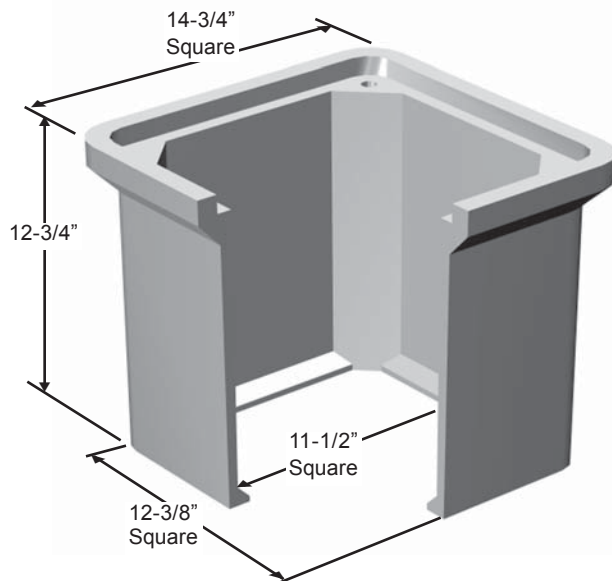

### BODY

#### Model:

HLW1212

### Tolerances

Cover +1/8"

Body +1/8"

Foot +1/16"

Height +1/4"

**Fasteners:** 2 each (optional 4 ea) 3/8-16 UNC, Stainless Steel, Hex Head with Washer; Options: size, quantity, type head  
**Cover Identification** is blank unless specified

#### Steel Covers Optional

**Boxes are stackable.** Vertical load ratings are stated for single boxes. For units with MOLDED OPENINGS, subtract 2 lbs from Unit Weight. Weights may vary slightly.

All information contained in this brochure was current at the time of printing. Because of Carson Industries' policy of ongoing research and development, the Company reserves the right to discontinue or update product information without notice.

Heavy Duty

# HLW1212

## polymer Concrete 12" Square H-10

### Carson Industries, LLC

1160 Nicole Court  
Glendora, CA 91740  
800-735-5566 • 909-592-6272  
Fax: 909-592-7971  
www.carsonind.com

### RAW MATERIAL SPECIFICATIONS

#### Polymer Concrete, H-10

Standard Test Method	Properties of Raw Material	ASTM Designation	Test Results
Compressive Strength of Polymer Concretes	Compressive Strength	C 579-96	11,000 psi
Flexural Strength and Modulus of Elasticity of Polymer Concretes	Flexural Strength Modulus of Elasticity	C 580-93	1,800 psi 2,900,000 psi
Chemical Resistance of Polymer Concretes	Chemical Resistance	C 267-97	Pass <sup>4</sup>
Determination of Impact Resistance by means of a Tup (falling weight)	Impact Resistance	D 2444-93	Pass

<sup>1</sup>AASHTO H-10, ASTM C 857, A-8, 8,000 lbs Design Load. Static Vertical Load Rating >22,880 lbf. SCTE Tier 10, 10,400 lb design load; 22,568 lbf minimum test load.

<sup>2</sup>Coefficient of Friction (ASTM C1028) >0.5

<sup>3</sup>Western Underground Committee, Guide 3.6

<sup>4</sup>Specimens exposed to ten reagents (alkalis, acids and petroleum distillates) experience <2% weight and dimensional change and retain >75% of average Compressive Strength. Listing of reagents and test reports available upon request.

#### VERTICAL AND LATERAL LOAD RATING (*Design Load; Test Load*)

##### All "H Series" Bodies and Covers

- C857 A-8, AASHTO, HS10-44 – 8,000 lbf; 22,880 lbf
- SCTE Tier 10 – 10,400 lbf; 22,568 lbf

### SHIPPING INFORMATION

	<u>Weight</u>
1212-P0Cover	10 lbs.
1212 Body	32 lbs.

#### Shipping Configuration

Unit, 36 assemblies = 62.0 cu. ft.; 1,512.0 lbs.

All information contained in this brochure was current at the time of printing. Because of Carson Industries' policy of ongoing research and development, the Company reserves the right to discontinue or update product information without notice.